

TRANSIT MIXER

XVJ 4001 / XC 6000



- « Unique drum design made of highly durable steel
- « Optimised positioned spirals with anti wear protection
- « Efficient hydraulics with planetary drive
- « Rugged, compact mixing units
- « On board water tank and pump for feeding water
- « Special loading hopper and unloading chute

XVJ 4001

MIXER DRUM

Nominal filling capacity	: 4000 liters
Geometric volume	: 6140 liters
Filling ratio	: 65 %
Rotation speed (both directions)	: 0-21 rpm
Diameter	: 1976 mm
Number of rollers	: 2
Drum angle	: 15°
Helix Anti-wear Sailma plate	: 5 mm

ENGINE

SIMPSON S433 water cooled, naturally aspirated, direct injection engine of 54 hp @ 2300 rpm

WATER SYSTEM

Water tank capacity	: 400 liters
Maximum pump output	: 250 lpm
Water pump pressure	: 3.5 bars

ELECTRICAL SYSTEM

Ignition : 12 volts

FILLING CAPACITIES

Gear box oil	: 2.75 liters
Hydraulic oil	: 35 liters
Engine oil	: 12.5 liters

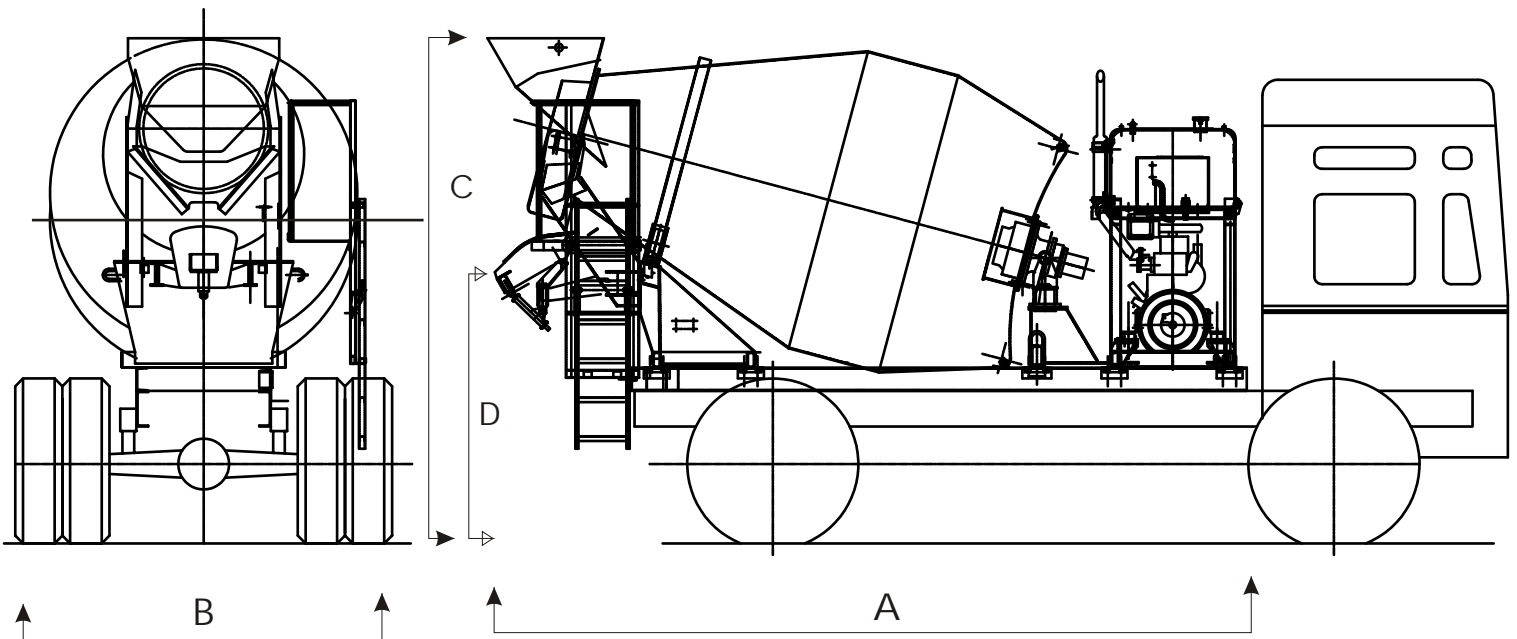

DIMENSIONS :

A Length of mixer	: 4835 mm
B Width of mixer	: 2420 mm
C Height of mixer	: 3245 mm
D Discharge height	: 1610 mm
Standard height for driving	: 3245 mm

WEIGHT :

Weight of mixer	: 2,750 Kgs
Weight of concrete	: 10,000 Kgs
Gross vehicle weight	: 12,750 Kgs

CHASSIS MOUNTING :

Can be mounted on 142"
Wheel base chassis-
Tata 1613 Tipper/
Ashok Leyland Comet

XC 6000

MIXER DRUM

Nominal filling capacity	: 6000 liters
Geometric volume	: 10650 liters
Filling ratio	: 56 %
Rotation speed (both directions)	: 0 - 14 rpm
Diameter	: 2270 mm
Number of rollers	: 2
Drum angle	: 15°
Helix Antiwear Sailma plate	: 5 mm

ENGINE

KOEL HA 494 aircooled, naturally aspirated, direct injection engine of 70 hp @ 2500 rpm

WATER SYSTEM

Water tank capacity	: 450 liters
Water pump output	: 250 lpm
Water pump pressure	: 3.5 bars

ELECTRICAL SYSTEM

Ignition : 24 V

FILLING CAPACITIES

Gear box oil	: 8 liters
Hydraulic oil	: 12.5 liters
Engine oil	: 12.5 liters

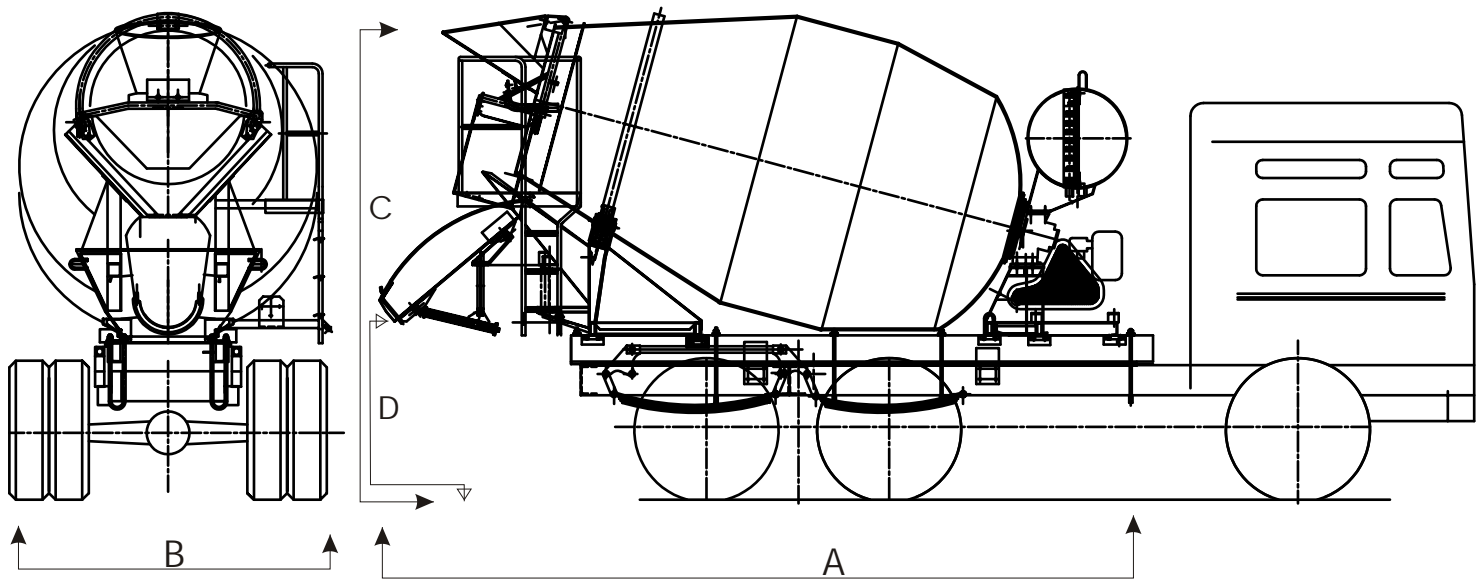

DIMENSIONS:

A Length of mixer	: 5920 mm
B Width of mixer	: 2270 mm
C Height of mixer	: 3695 mm
D Discharge height	: 1355 mm
Standard height for driving	: 3685 mm

WEIGHT :

Weight of Mixer	: 3,750 Kgs
Weight of concrete	: 15,000 Kgs
Gross vehicle weight	: 18,750 Kgs

CHASSIS MOUNTING :

Can be mounted on 150" / 180"
Wheelbase chassis 2516-
Tata/Ashok Leyland/AMW/MAN



APPLICATIONS



Pub No.: Transit Mixer/02/April/10/Issue 01

Specifications are subject to change without prior notice



AJAX FIORI ENGINEERING (INDIA) PRIVATE LIMITED
Joint Venture - FIORI S.p.A. Italy

148 / 25, Industrial Suburb, Yeshwanthpur, Bangalore - 560 022
Tel : 080 2337 7490 / 2977 / 3439, Fax : 080 2337 9510
Email : info@ajax-fiori.com, Website: www.ajax-fiori.com

For Sales Queries : 99028 26628 / 98800 42628