

AJAX FIORI

**SELF LOADING
SITE DUMPER**

DX 25 SL

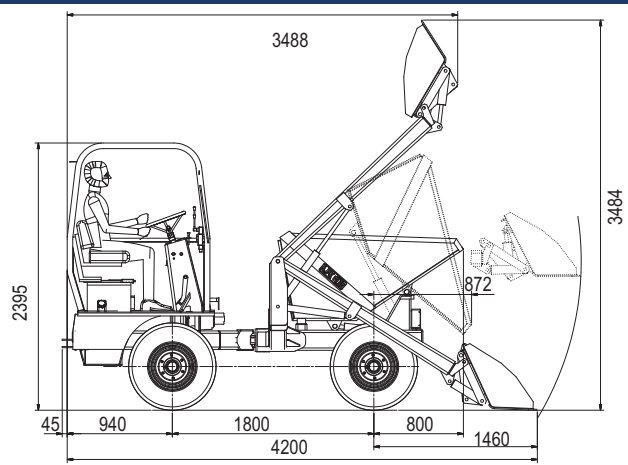

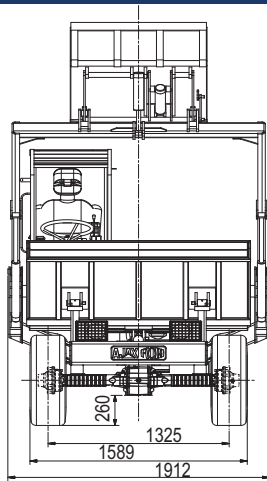

Short turning radius: 4.2 meters



Oscillation



Hydraulic powered self loading



Ergonomic Controls



Articulation angle : 30 degrees



Loading shovel

ENGINE:

Mahindra & Mahindra water cooled 4 stroke diesel engine - 28.7 kw @2600 rpm
BS III CEV Emission Certified.

CHASSIS:

Articulated, High tensile steel welded "C" type construction.

TRANSMISSION:

4 wheel drive, with hydrostatic transmission.

Vehicle speed - 0 to 6 Km/h (Low)
0 to 11 Km/h (High)

AXLES:

Full floating hypoid type fixed front and rear axle.

BRAKES

Power braking with oil cooled disc type brakes on all 4 wheels actuated by independent pump. Hand operated parking brake by cable.

ELECTRICAL SYSTEM

Battery: 12V, 80 Amp-hr.
Complete lighting & signaling system as per CMVR standards.

HYDRAULIC SYSTEM

Gear type pump control in the cylinder to lift the skip body
Output : 18.28 lpm
pressure : 160 bar

STEERING

Fully powered hydraulic steering by cylinder, operated through independent gear pump.

SELF LOADING SYSTEM:

Single joystick controlled hydrostatic cylinders operated loading shovel of 165 L.

SKIP

Heaped capacity : 1585 ltrs
Struck capacity : 1240 ltrs

SERVICE REFILL CAPACITIES

Fuel tank : 34 litres
Hydraulic tank : 45 litres

WHEEL

Tyre : 10.0/75-15.3 - 18 PR
Rim size : 9 x 15

WEIGHT

Net vehicle weight : 2300 kgs
Gross vehicle weight : 4800 kgs

Specifications are subject to change without prior notice



AJAX FIORI ENGINEERING (INDIA) PRIVATE LIMITED

Joint Venture - FIORI S.p.A. Italy

148 / 25, Industrial Suburb, Yeshwanthpur, Bangalore - 560 022

Tel : 080 3921 1000, Fax : 080 2347 1757

Email : info@ajax-fiori.com, Website: www.ajax-fiori.com

For Sales Queries : 99028 26628 / 98800 42628

Factory: 16 & 17, KIADB Industrial Area, Bashettihalli, Doddaballapur - 561 203 Tel : 080 3921 6001, Fax : 080 3921 6004